

INSTRUCCIONES DE REPARACIÓN

Sustitución de la junta del marco de las tapas cuadradas

FIBRELITE
PART OF OPW A DOWDER COMPANY

INTRODUCCIÓN

La junta se compone de dos cosas, una junta de goma y un tubo de nylon. Para cambiar la junta existente siga las siguientes instrucciones usando los accesorios de montaje que se muestran a continuación:

Equipo necesario



Grasa de silicona

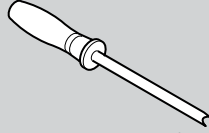

Herramienta de montaje del tubo

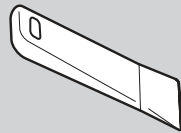

Cuchilla

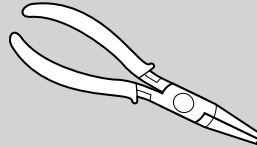

Alicates

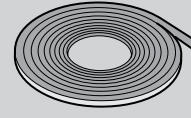

Tubo de nylon

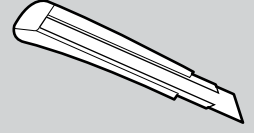

Cutter

Quitar la junta

1

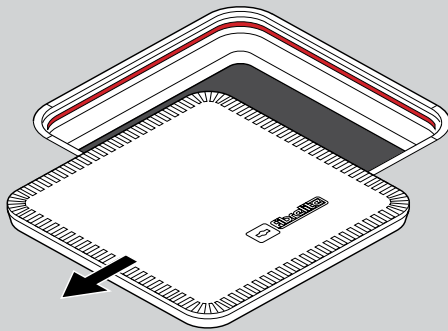

Quite la tapa.

2

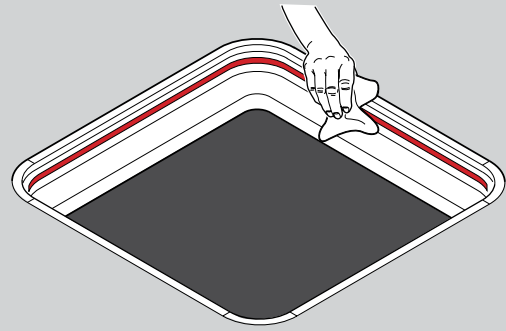

Limpie la suciedad del marco de la junta.

3

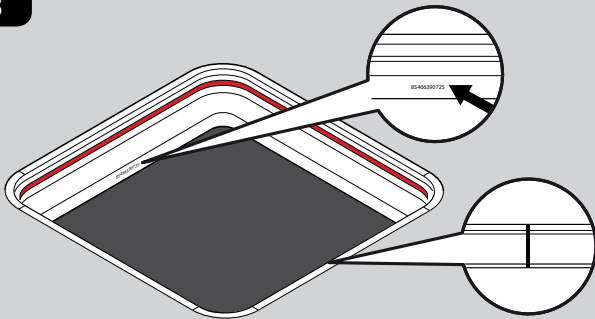

Localice la unión en el tubo de nylon. Está situada sobre el número de serie del marco en una de las caras verticales.

4

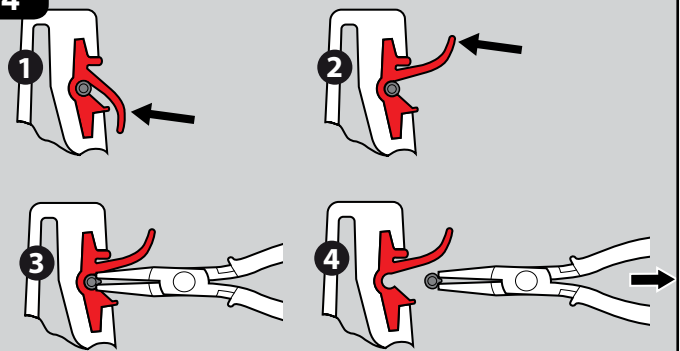

Levante la junta para descubrir el tubo. Con unos alicates, pellizque el tubo, tire de él y deséchelo.

5

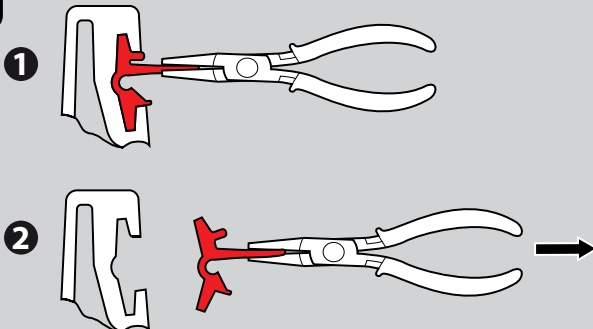

Sujete la junta con unos alicates y tire de ella horizontalmente.

6

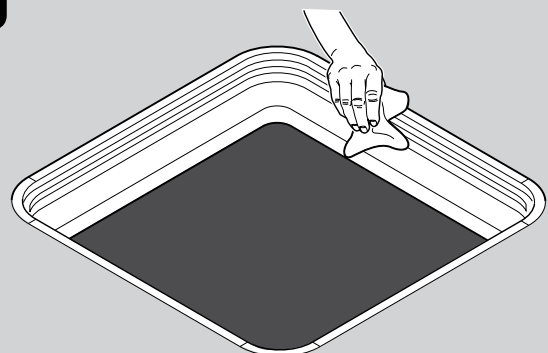

Limpie otra vez el marco antes de colocar la junta nueva.

7

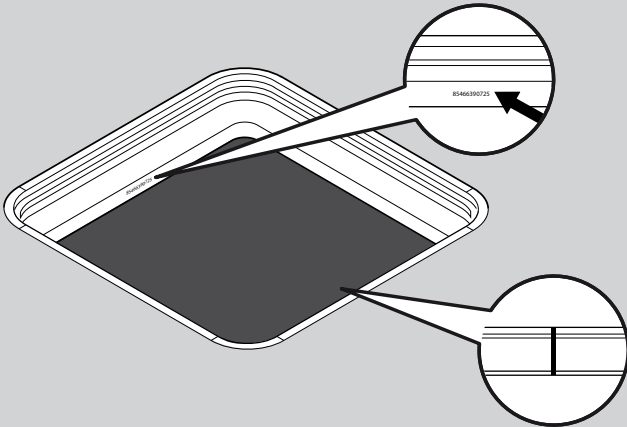

La junta nueva tiene una unión vertical. Empiece this joint directly opposite to the frame serial number.

8

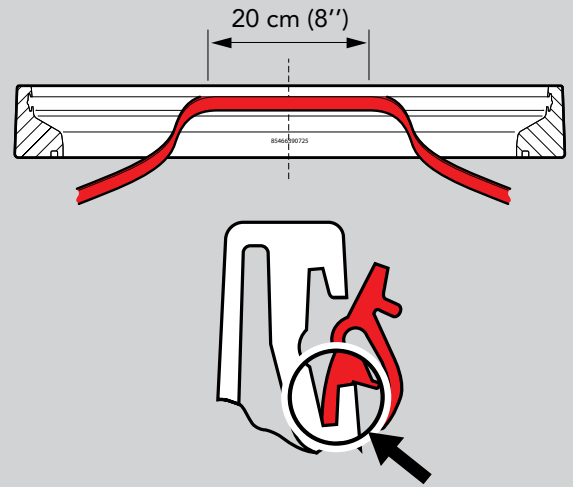

'Tuck' the seal bottom lip into the extrusion seal housing for approximately 20 cm (8")

9

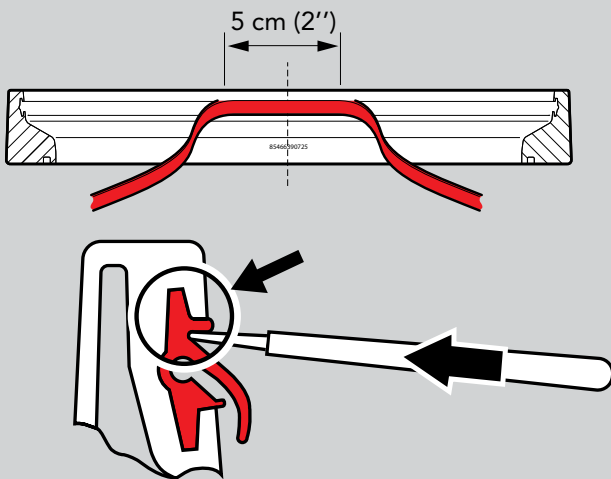

Using a round edged blade 'tuck' approximately 5cm (2") of the seal top lip into the housing start point.

10

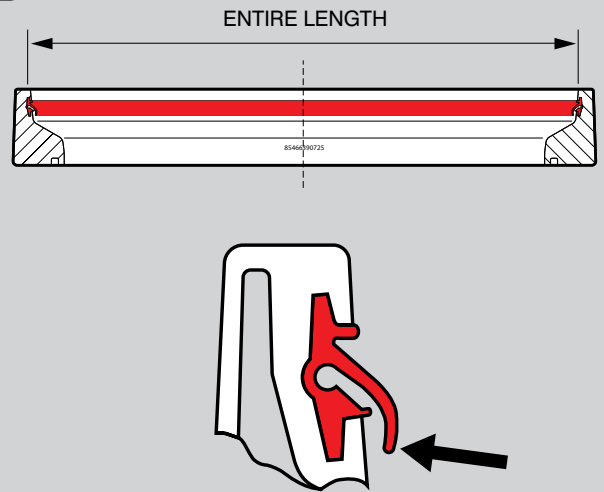

Now 'tuck' the silicone seal bottom lip into the frame around its entire length.

11

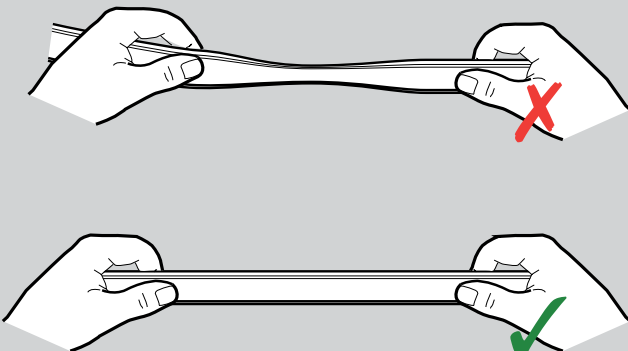

Avoid stretching during application.

12



Apply a light coating silicone grease to the seal.

13

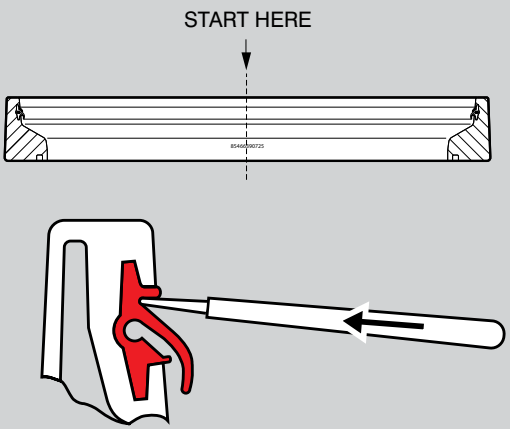

START HERE

Starting at the moulded seal joint push the seal top lip into the extrusion seal housing by running the blade along the the seal top lip.

14

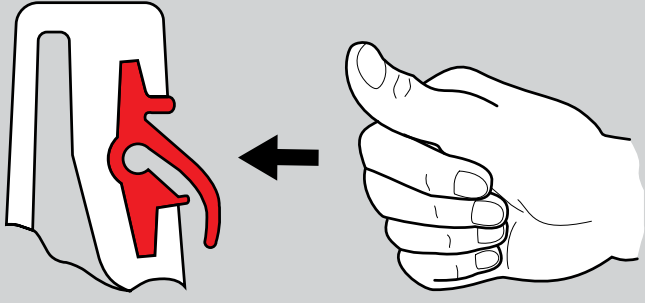

Ensure the seal is seated correctly by applying hand pressure to the front face of the seal.

15

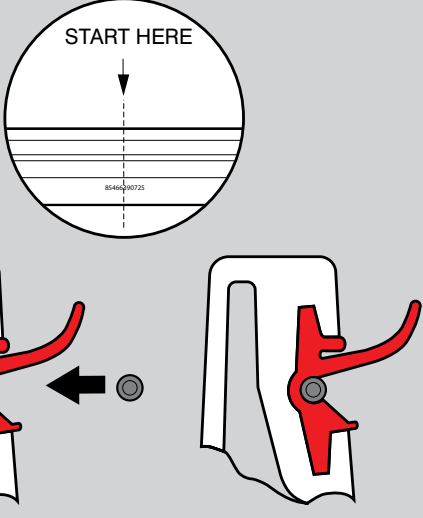

START HERE

Starting at the frame serial number, lift the seal and insert the new nylon tube into the seal tube housing.

16

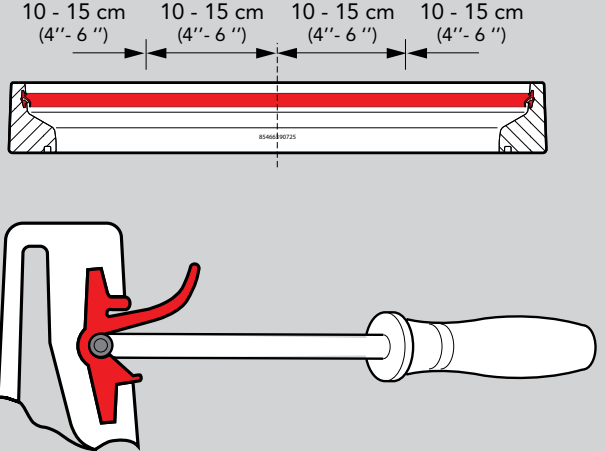

10 - 15 cm (4'' - 6'')

10 - 15 cm (4'' - 6'')

10 - 15 cm (4'' - 6'')

10 - 15 cm (4'' - 6'')

Put the fitting tool onto the nylon tube and run the tube into position whilst holding the main seal open. Perform this operation in stages of 10-15 cm (4'' - 6'').

17

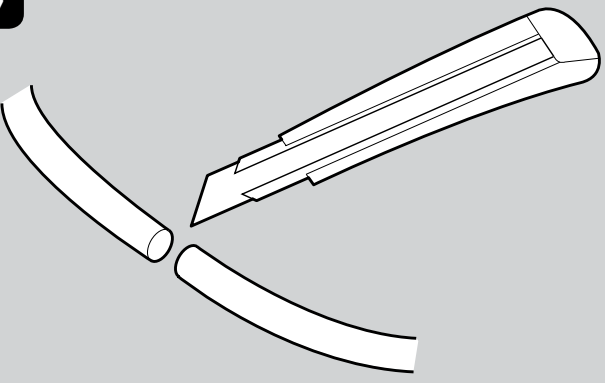

Trim excess tube with Stanley knife.